

REVISIONS			
REV.	DESCRIPTION	DATE	APPROVED
A	INITIAL RELEASE	7/9/09	GMK

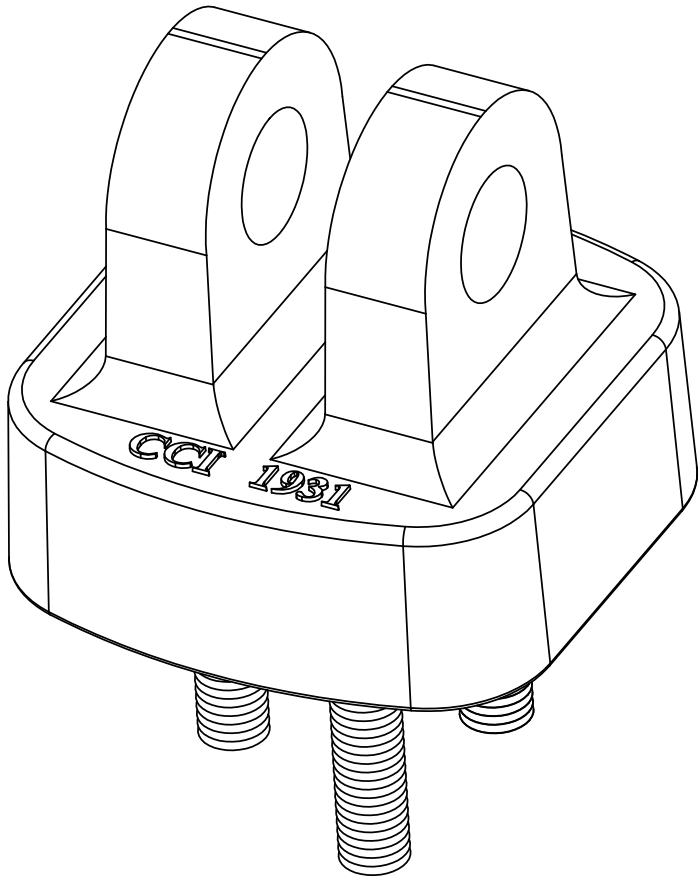

ITEM NO.	PART DESCRIPTION	
5104-DB	1931 Tri-Stud Double-Eared Balancer, Al Alloy 535.0, SS304 Bushings (2), Cast-In 5/16"-18 SS304 Studs (3)	1

	NAME	DATE
DRAWN	JRK	6/20/09
CHECKED	GMK	6/20/09
ENG APPR.	AMK	6/24/09
MFG APPR.	JRL	6/25/09

PROPRIETARY AND CONFIDENTIAL
 THE INFORMATION CONTAINED IN THIS DRAWING IS THE SOLE PROPERTY OF COST CAST, INC. ANY REPRODUCTION IN PART OR AS A WHOLE WITHOUT THE WRITTEN PERMISSION OF COST CAST, INC. IS PROHIBITED.

UNLESS OTHERWISE SPECIFIED:			<p style="text-align: center;">COST CAST, INC</p> <p style="text-align: center;">1931</p> <p style="text-align: center;">Tri-Stud, Double-Eared Balancer</p>		
DIMENSIONS ARE IN INCHES TOLERANCES: ANGULAR: MACH $\pm 1/32$ " TWO PLACE DECIMAL $\pm .03$ " THREE PLACE DECIMAL $\pm .010$ "					
INTERPRET GEOMETRIC TOLERANCING PER:					
MATERIAL VARIOUS		SIZE A	DWG. NO. 13693		REV A
FINISH VARIOUS		SCALE: 1:8		WEIGHT:	SHEET 1 OF 1
DO NOT SCALE DRAWING					